



# 650V Super-junction Power MOSFET

## Description

### 650V Super-junction Power MOSFET

Super-junction power MOSFET is a revolutionary technology for high voltage power MOSFETs, designed according to the SJ principle. The deep trench SJ MOSFET provide an extremely low switching, commutation and conduction losses device with highest robustness make especially resonant switching applications more reliable, more efficient, lighter and cooler, designed by Wuxi Unigroup Microelectronics Company.

## Features

- Very low FOM  $R_{DS(on)} \times Q_g$
- 100% avalanche tested
- Easy to use/drive
- RoHS compliant

## Applications

- Switch Mode Power Supply (SMPS)
- Uninterruptible Power Supply (UPS)
- Power Factor Correction (PFC)
- Charger

TO-220F



TO-263



TO-252

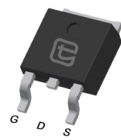

Drain

Gate

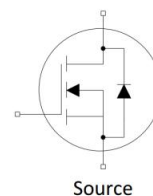

Source



## Device Marking and Package Information

Device	Package	Marking
TPA65R520D	TO-220F	65R520D
TPB65R520D	TO-263	65R520D
TPD65R520D	TO-252	65R520D

## Key Performance Parameters

Parameter	Value	Unit
$V_{DS} @ T_{j,max}$	700	V
$R_{DS(on),max}$	0.52	$\Omega$
$Q_{g,typ}$	12.5	nC
$I_D$	7	A
$I_{D,pulse}$	21	A
$E_{OSS} @ 400V$	1.66	$\mu J$



Absolute Maximum Ratings $T_C = 25^\circ\text{C}$ , unless otherwise noted				
Parameter		Symbol	Values	Unit
Continuous Drain Current	$T_C = 25^\circ\text{C}$	$I_D$	7	A
	$T_C = 100^\circ\text{C}$		4	
Pulsed Drain Current	(note1)	$I_{D,pulse}$	21	A
Gate-Source Voltage		$V_{GSS}$	$\pm 30\text{V}$	V
Single Pulse Avalanche Energy	(note2)	$E_{AS}$	45	mJ
Repetitive Avalanche Energy	(note2)	$E_{AR}$	0.28	mJ
Avalanche Current		$I_{AR}$	3	A
MOSFET dv/dt Ruggedness, $V_{DS} = 0 \dots 480\text{V}$		dv/dt	50	V/ns
Power Dissipation For TO-220F		$P_D$	28	W
Power Dissipation For TO-263, TO-252			62.5	
Continuous Diode Forward Current		$I_S$	7	A
Diode Pulsed Current	(note1)	$I_{S,pulse}$	21	
Reverse Diode dv/dt	(note3)	dv/dt	5	V/ns
Operating Junction and Storage Temperature Range		$T_J, T_{stg}$	$-55 \sim +150$	$^\circ\text{C}$

Thermal Resistance For TO-220F			
Parameter	Symbol	Value	Unit
Thermal Resistance, Junction-to-Case	$R_{thJC}$	4.5	$^\circ\text{C}/\text{W}$
Thermal Resistance, Junction-to-Ambient	$R_{thJA}$	80	

Thermal Resistance For TO-263, TO-252			
Parameter	Symbol	Value	Unit
Thermal Resistance, Junction-to-Case	$R_{thJC}$	2	$^\circ\text{C}/\text{W}$
Thermal Resistance, Junction-to-Ambient	$R_{thJA}$	62	



Electrical Characteristics $T_J = 25^\circ\text{C}$ , unless otherwise noted						
Parameter	Symbol	Test Conditions	Value			Unit
			Min.	Typ.	Max.	
<b>Static Characteristics</b>						
Drain-Source Breakdown Voltage	$V_{(BR)DSS}$	$V_{GS} = 0V, I_D = 250\mu\text{A}$	650	--	--	V
Zero Gate Voltage Drain Current	$I_{DSS}$	$V_{DS} = 650V, V_{GS} = 0V, T_J = 25^\circ\text{C}$	--	--	1	$\mu\text{A}$
		$V_{DS} = 650V, V_{GS} = 0V, T_J = 150^\circ\text{C}$	--	--	100	
Gate-Source Leakage Current	$I_{GSS}$	$V_{GS} = \pm 30V$	--	--	$\pm 100$	nA
Gate-Source Threshold Voltage	$V_{GS(th)}$	$V_{DS} = V_{GS}, I_D = 250\mu\text{A}$	2.5	--	4.0	V
Drain-Source On-State-Resistance	$R_{DS(on)}$	$V_{GS} = 10V, I_D = 3A$	--	0.44	0.52	$\Omega$
<b>Dynamic Characteristics</b>						
Input Capacitance	$C_{iss}$	$V_{GS} = 0V,$ $V_{DS} = 100V,$ $f = 1.0\text{MHz}$	--	564	--	$\mu\text{F}$
Output Capacitance	$C_{oss}$		--	22	--	
Reverse Transfer Capacitance	$C_{rss}$		--	0.5	--	
Total Gate Charge	$Q_g$	$V_{DD} = 520V, I_D = 7A,$ $V_{GS} = 10V$	--	12.5	--	nC
Gate-Source Charge	$Q_{gs}$		--	5	--	
Gate-Drain Charge	$Q_{gd}$		--	3.2	--	
Turn-on Delay Time	$t_{d(on)}$	$V_{DD} = 400V, I_D = 7A,$ $R_G = 25\Omega$	--	52	--	ns
Turn-on Rise Time	$t_r$		--	62	--	
Turn-off Delay Time	$t_{d(off)}$		--	84	--	
Turn-off Fall Time	$t_f$		--	50	--	
<b>Drain-Source Body Diode Characteristics</b>						
Body Diode Forward Voltage	$V_{SD}$	$T_J = 25^\circ\text{C}, I_{SD} = 7A, V_{GS} = 0V$	--	0.9	1.2	V
Reverse Recovery Time	$t_{rr}$	$V_R = 400V, I_S = 3A,$ $di_F/dt = 100\text{A}/\mu\text{s}$	--	200	--	ns
Reverse Recovery Charge	$Q_{rr}$		--	1.6	--	$\mu\text{C}$
Peak Reverse Recovery Current	$I_{rrm}$		--	3.2	--	A

**Notes**

1. Repetitive Rating: Pulse width limited by maximum junction temperature
2.  $I_D = 10A, V_{DD} = 50V, R_G = 25\Omega$ , Starting  $T_J = 25^\circ\text{C}$
3. Identical low side and high side switch with identical  $R_G$



Typical Characteristics  $T_J = 25^\circ\text{C}$ , unless otherwise noted

Figure 1. Output Characteristics

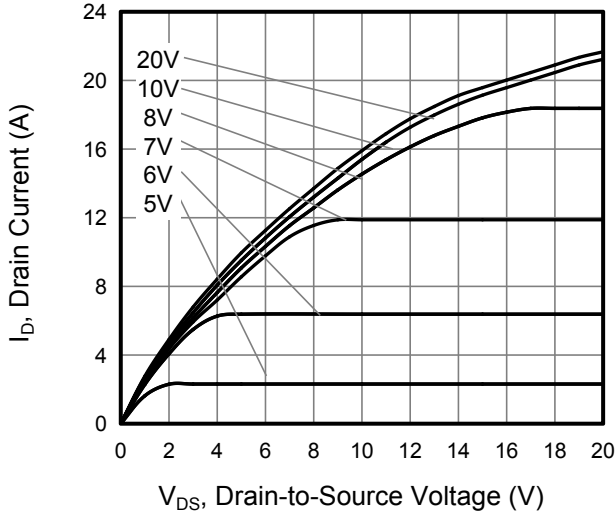

Figure 2. Transfer Characteristics

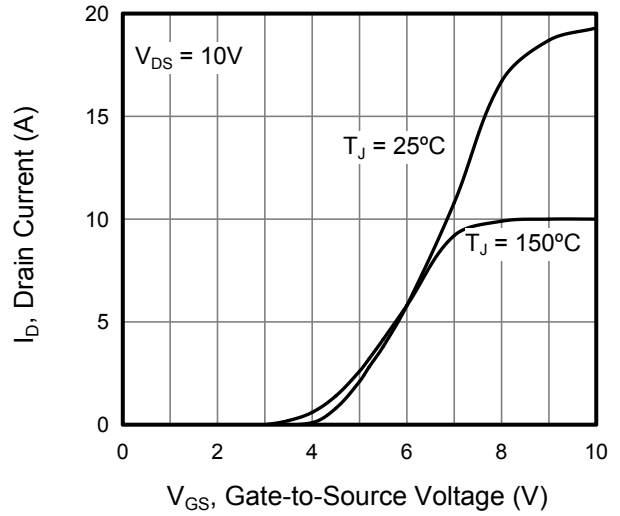

Figure 3. On-Resistance vs. Drain Current

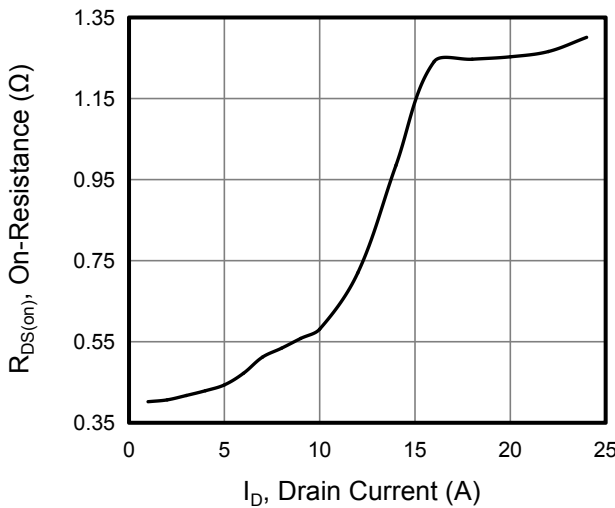

Figure 4. Capacitance

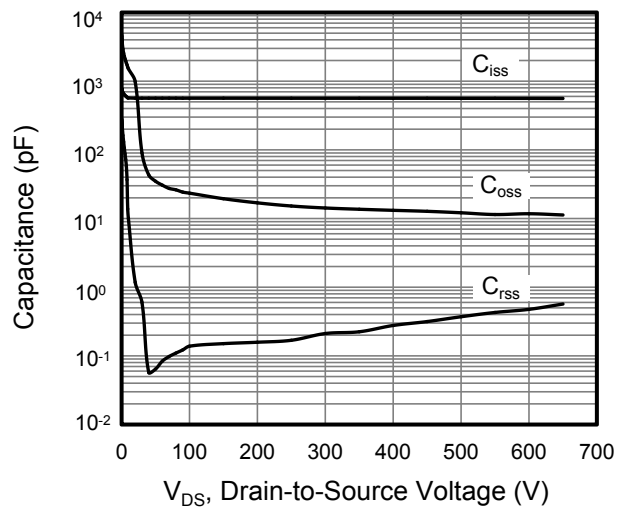

Figure 5. Gate Charge

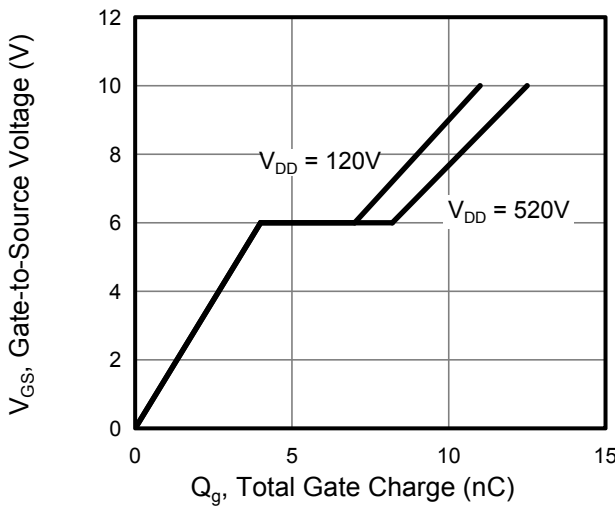

Figure 6. Body Diode Forward Voltage

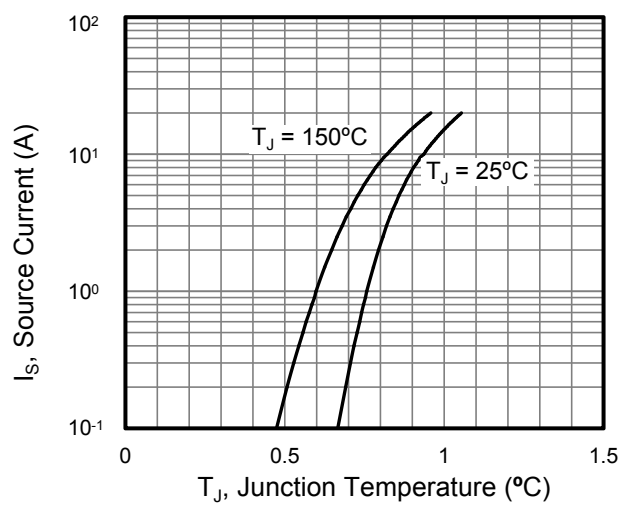



Figure 7. On-Resistance vs. Temperature

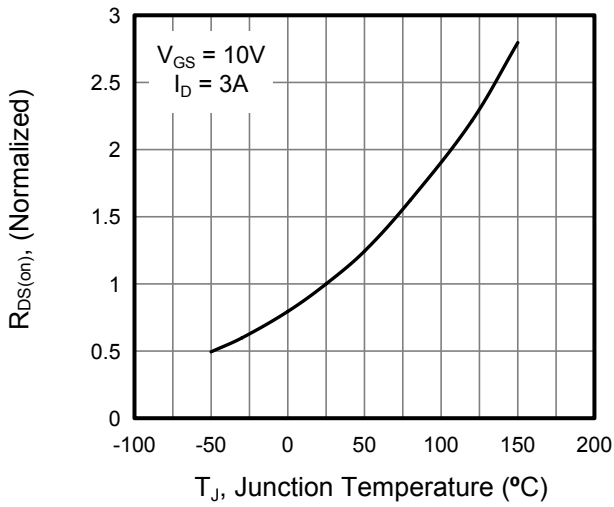

Figure 8. Breakdown voltage vs. Junction Temperature

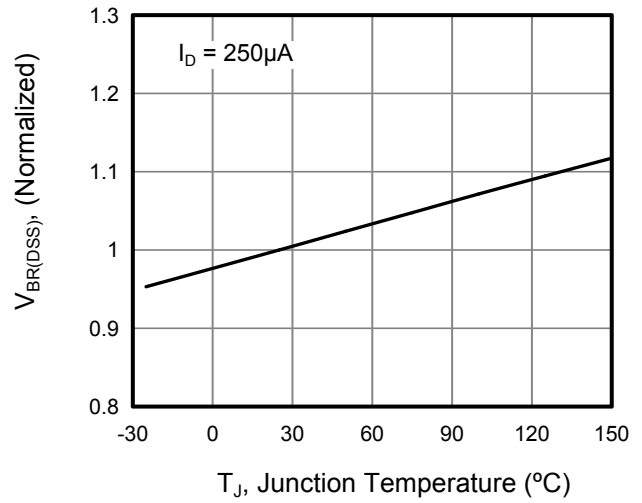

Figure 9. Transient Thermal Impedance For TO-263/TO-252

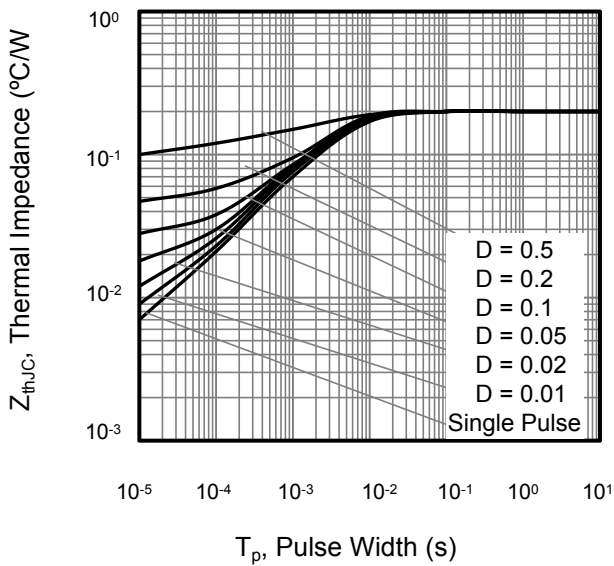

Figure 10. Safe Operation Area For TO-263/TO-252

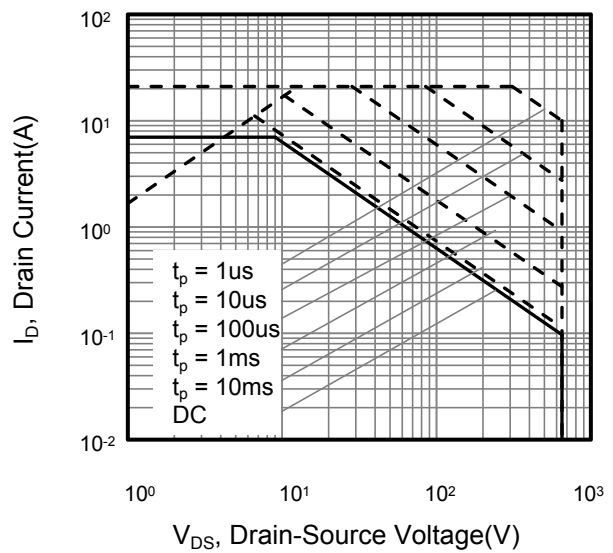

Figure 11. Transient Thermal Impedance For TO-220F

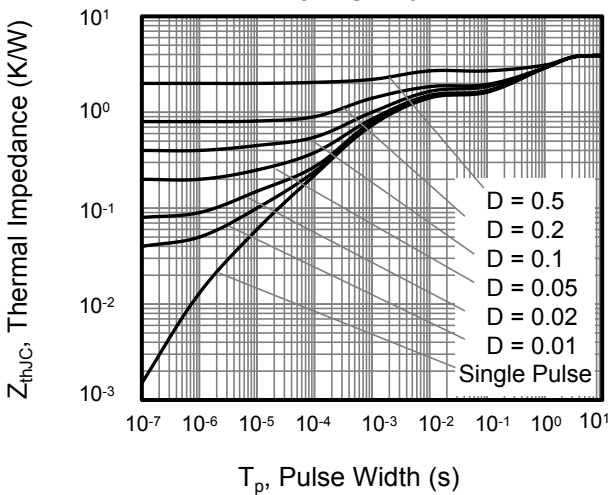
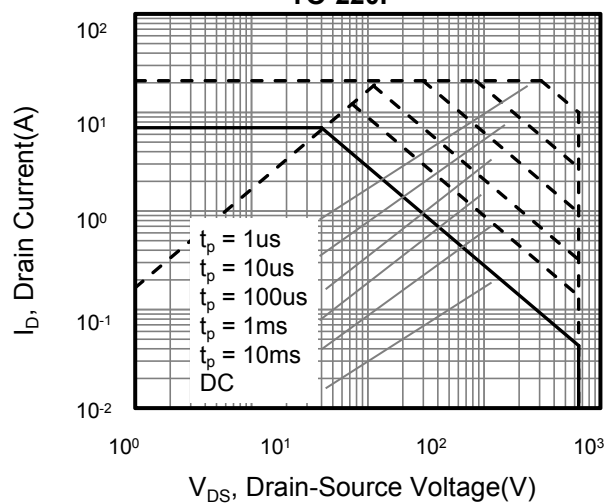

Figure 12. Safe Operation Area For TO-220F





Typical Characteristics  $T_J = 25^\circ\text{C}$ , unless otherwise noted

Figure 13. Typ. Coss Stored Energy

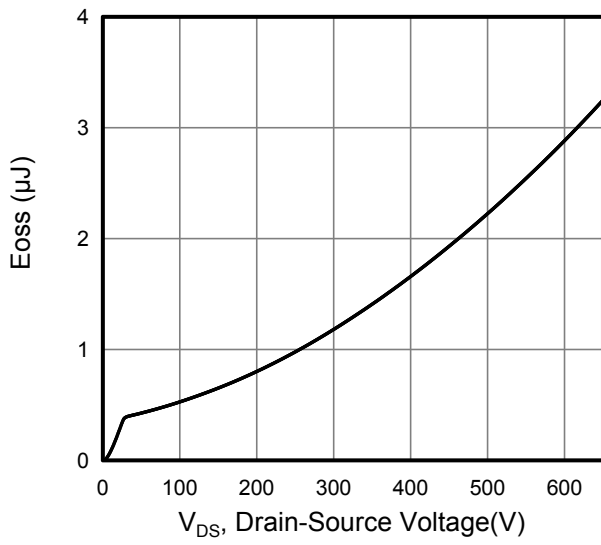



Figure A: Gate Charge Test Circuit and Waveform

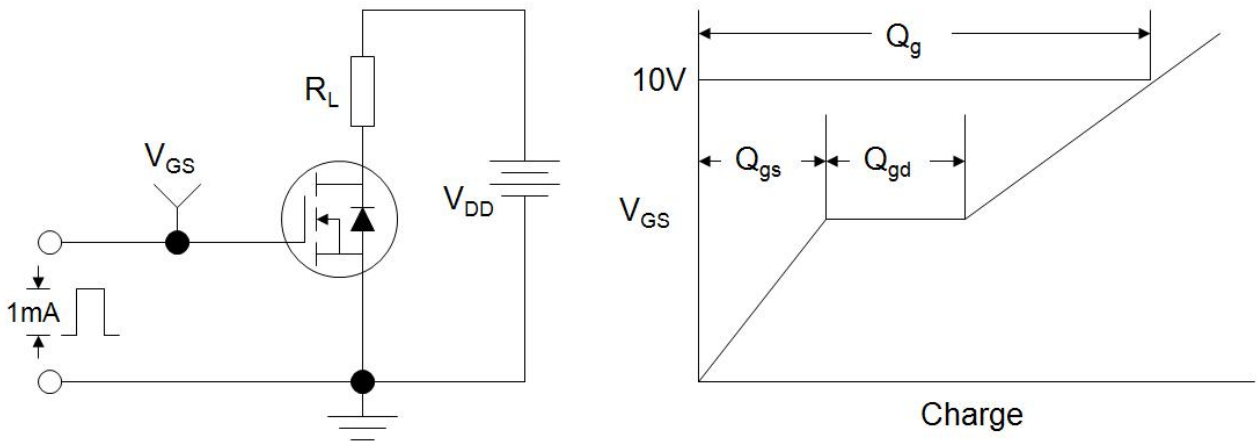

Figure B: Resistive Switching Test Circuit and Waveform

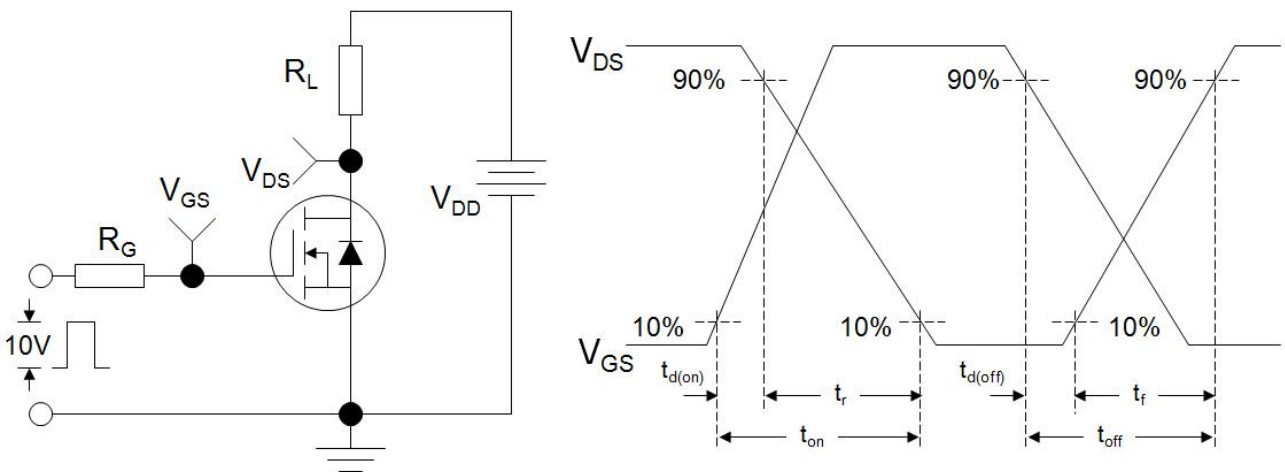
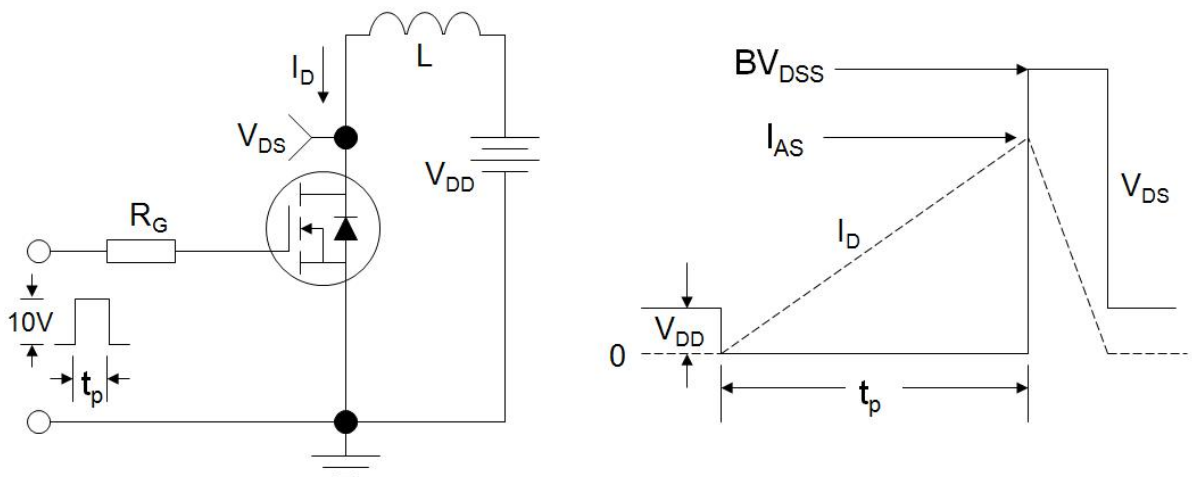
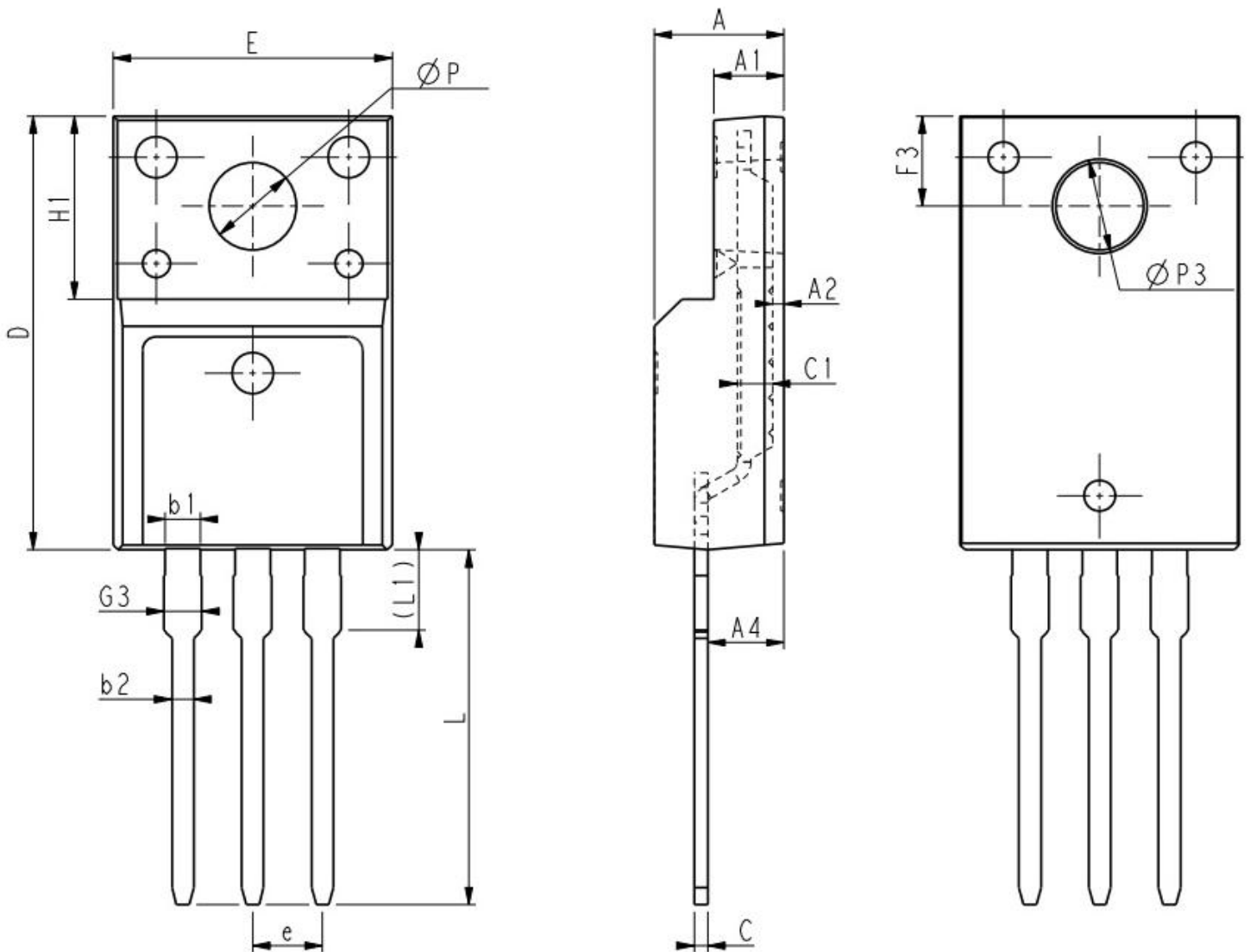

Figure C: Unclamped Inductive Switching Test Circuit and Waveform





**TO-220F (封装厂 H)**



Unit:mm			
Symbol	Min.	Nom	Max.
E	9.96	10.16	10.36
A	4.50	4.70	4.90
A1	2.34	2.54	2.74
A2	0.30	0.45	0.60
A4	2.56	2.76	2.96
c	0.40	0.50	0.65
c1	1.20	1.30	1.35
D	15.57	15.87	16.17
H1	6.70REF		

Unit:mm			
Symbol	Min.	Nom	Max.
e	2.54BSC		
L	12.68	12.98	13.28
L1	2.93	3.03	3.13
$\Phi P$	3.03	3.18	3.38
$\Phi P3$	3.15	3.45	3.65
F3	3.15	3.30	3.45
G3	1.25	1.35	1.55
b1	1.18	1.28	1.43
b2	0.70	0.80	0.95





TO-220F (封装厂 I)

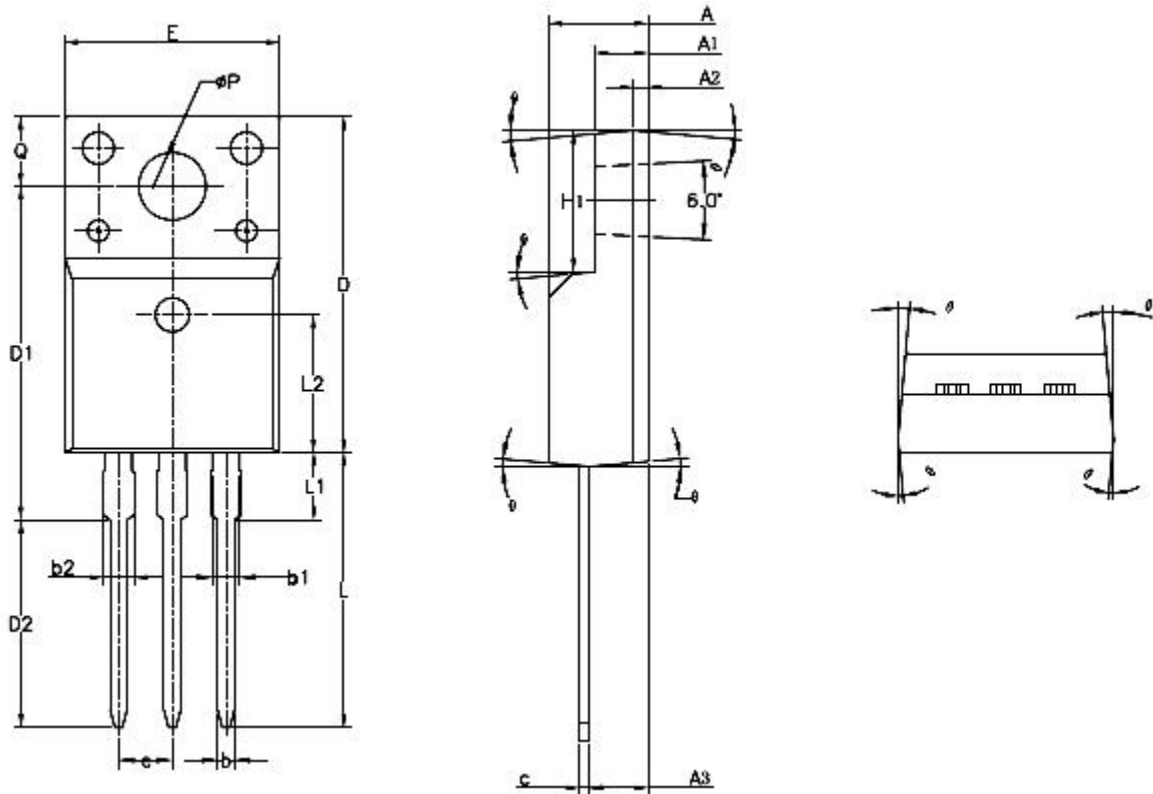

SYMBOL	MIN	NOM	MAX
A	4.50	4.70	4.83
A1	2.34	2.54	2.74
A2	0.70 REF		
A3	2.56	2.76	2.93
b	0.70	—	0.90
b1	1.18	—	1.38
b2	—	—	1.47
c	0.45	0.50	0.60
D	15.67	15.87	16.07
D1	15.55	15.75	15.95
D2	9.60	9.80	10.0
E	9.96	10.16	10.36
e	2.54BSC		
H1	6.48	6.68	6.88
L	12.68	12.98	13.28
L1	—	—	3.50
L2	6.50REF		
$\phi P$	3.08	3.18	3.28
Q	3.20	—	3.40
$\theta 1$	1°	3°	5°



TO-263 (封装厂 I)

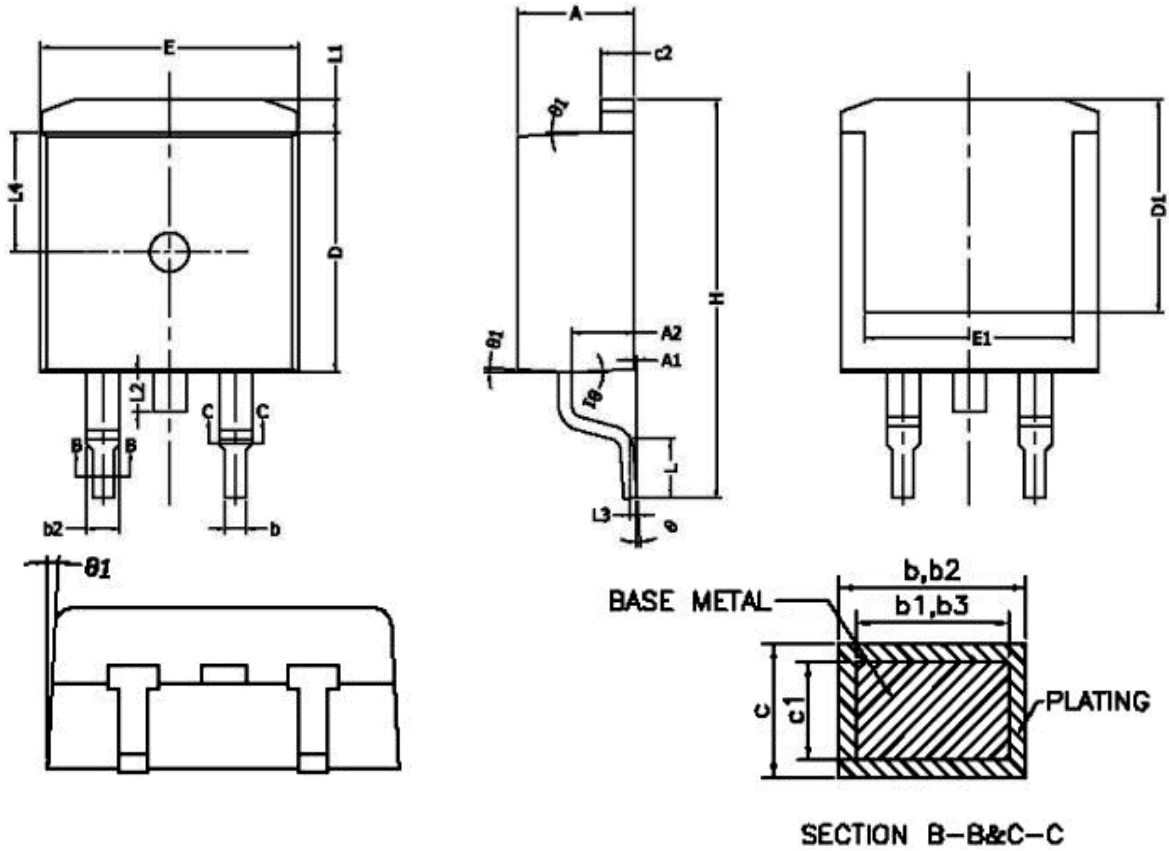

SYMBOL	MIN	NOM	MAX
A	4.40	4.50	4.60
A1	0	0.10	0.25
A2	2.20	2.40	2.60
b	0.76	--	0.89
b1	0.75	0.80	0.85
b2	1.23	--	1.37
b3	1.22	1.27	1.32
c	0.47	--	0.60
c1	0.46	0.51	0.56
c2	1.25	1.30	1.35
D	9.10	9.20	9.30
D1	8.00	--	--
E	9.80	9.90	10.00
E1	7.80	--	--
e	2.54 BSC		
H	14.90	15.30	15.70
L	2.00	2.30	2.60
L1	1.17	1.27	1.40
L2	--	--	1.75
L3	0.25BSC		
L4	4.60 REF		
θ	0°	--	8°
θ1	1°	3°	5°



TO-252 (封装厂 H)

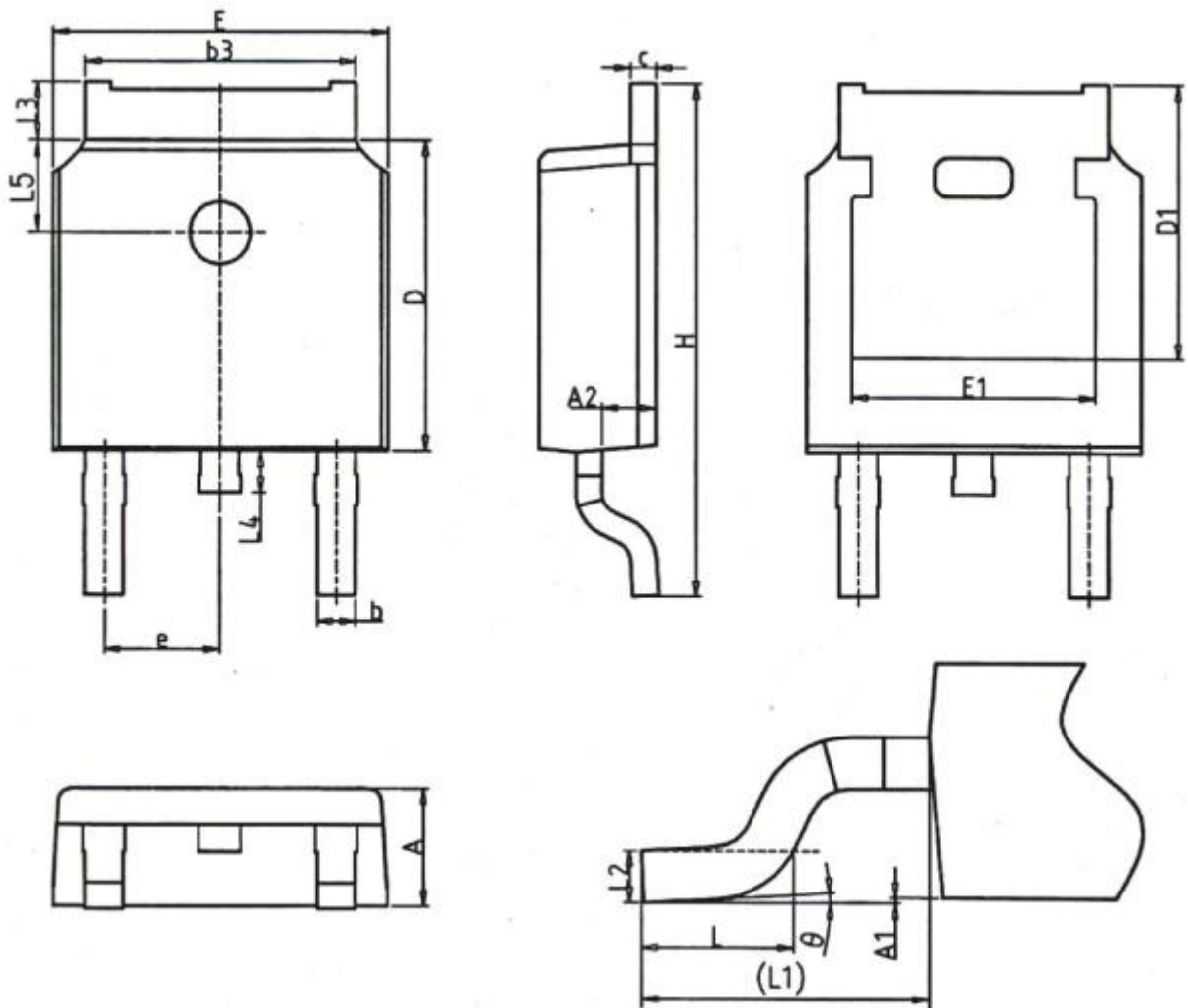

Unit:mm			
Symbol	Min.	Nom	Max.
A	2.20	2.30	2.38
A1	0.00	-	0.20
A2	0.97	1.07	1.17
b	0.68	0.78	0.90
b3	5.20	5.33	5.46
c	0.43	0.53	0.61
D	5.98	6.10	6.22
D1	5.30 REF		
E	6.40	6.60	6.73
E1	4.63	-	-

Unit:mm			
Symbol	Min.	Nom	Max.
e	2.286 BSC		
H	9.40	10.10	10.50
L	1.38	1.50	1.75
L1	2.90 REF		
L2	0.51 BSC		
L3	0.88	-	1.28
L4	0.50	-	1.00
L5	1.65	1.80	1.95
$\theta$	0°	-	8°



### TO-252 (封装厂 I)

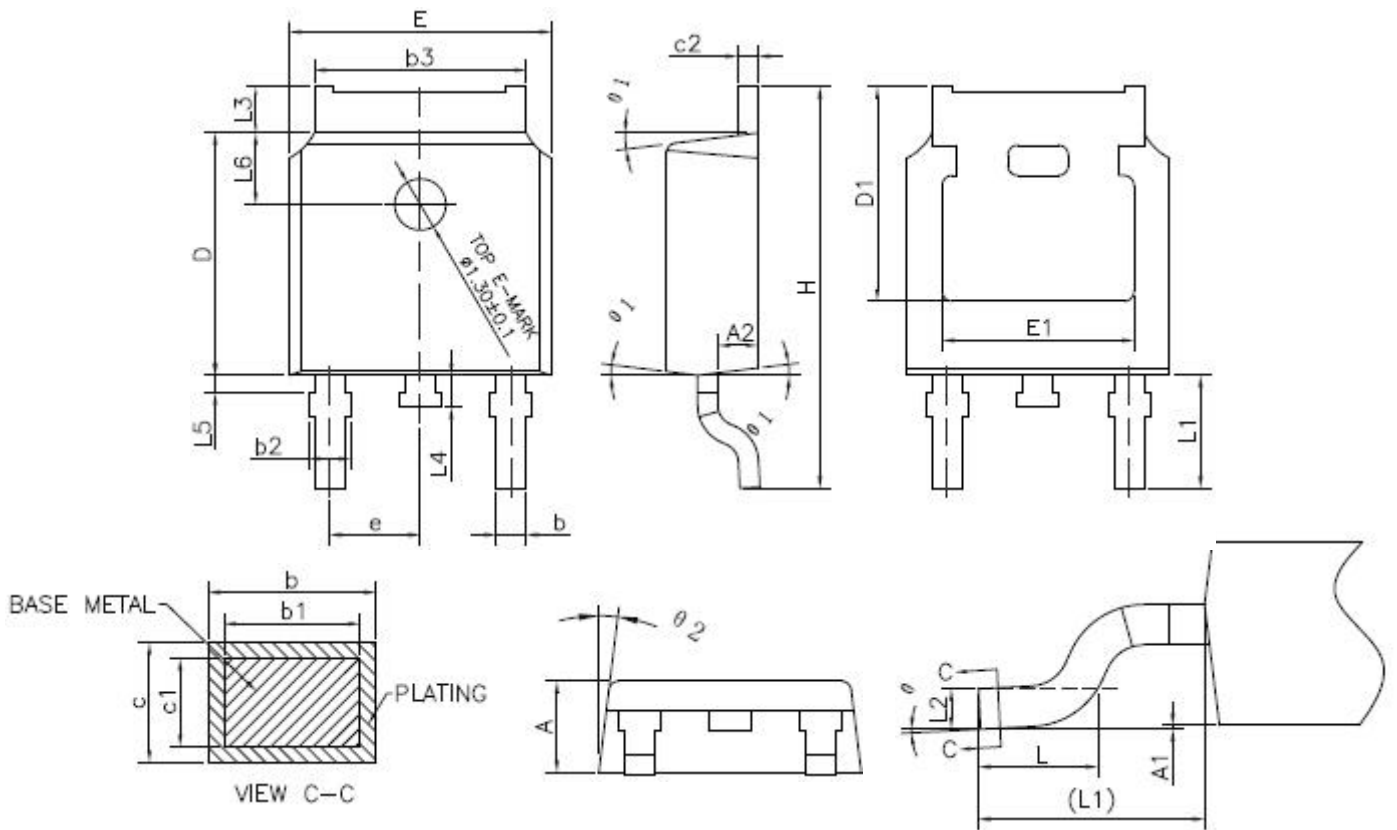

SYMBOL	MIN	NOM	MAX
A	2,20	2,30	2,38
A1	0	—	0,10
A2	0,90	1,01	1,10
b	0,72	—	0,85
b1	0,71	0,76	0,81
b2	0,72	—	0,90
b3	5,13	5,33	5,46
c	0,47	—	0,60
c1	0,46	0,51	0,56
c2	0,47	—	0,60
D	6,00	6,10	6,20
D1	5,25	—	—
E	6,50	6,60	6,70
E1	4,70	—	—
e	2,186	2,286	2,386
H	9,80	10,10	10,40
L	1,40	1,50	1,70
L1	2,90 REF		
L2	0,508 BSC		
L3	0,90	—	1,25
L4	0,60	0,80	1,00
L5	0,15	—	0,75
L6	1,80 REF		
$\theta$	0°	—	8°
$\theta_1$	5°	7°	9°
$\theta_2$	5°	7°	9°



TO-252 (封装厂 E)

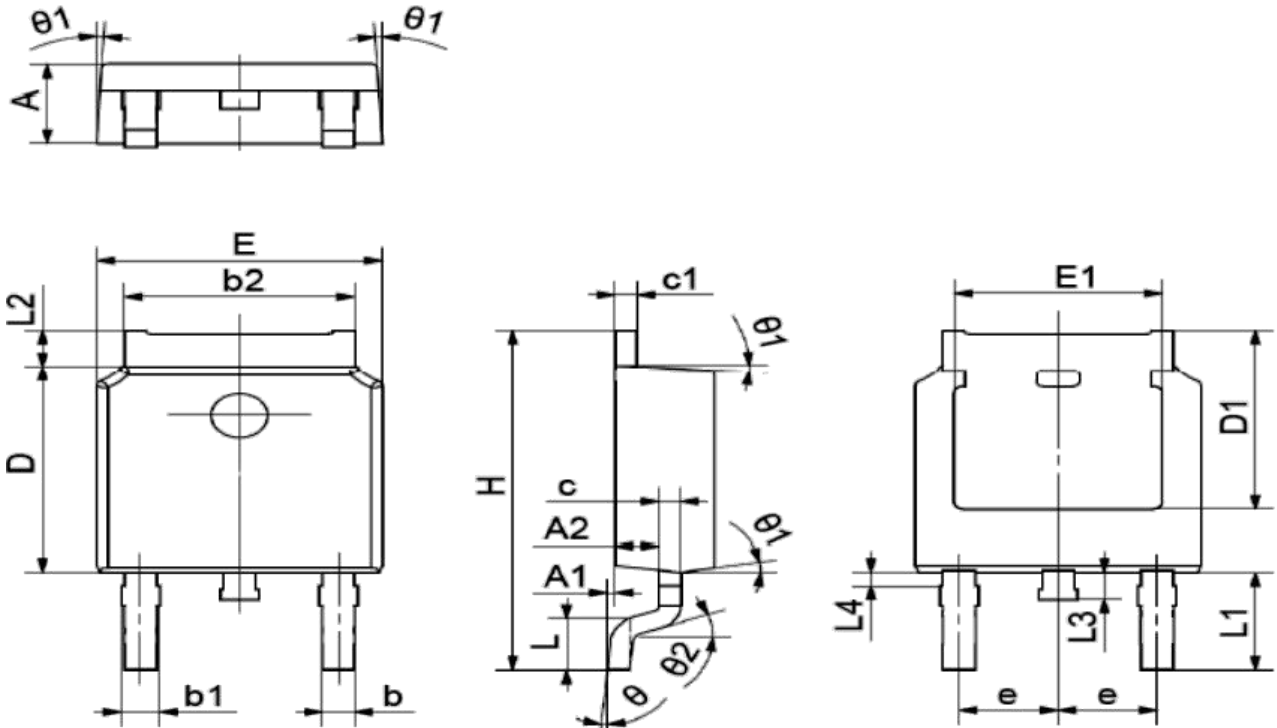

Symbol	Dimensions In Millimeters		Dimensions In Inches	
	Min.	Max.	Min.	Max.
A	2.10	2.50	0.083	0.098
A1	0	0.15	0.000	0.006
A2	0.76	1.36	0.030	0.054
b	0.61	0.85	0.024	0.033
b1	0.71	0.91	0.028	0.036
b2	5.04	5.64	0.198	0.222
c	0.508 TYP.		0.02 TYP.	
c1	0.508 TYP.		0.02 TYP.	
D	5.8	6.3	0.228	0.248
D1	5	5.6	0.197	0.220
E	6.3	6.9	0.248	0.272
E1	4.55	5.15	0.179	0.203
e	2.286 TYP.		0.09 TYP.	
H	9.65	10.4	0.380	0.409
L	1.4	1.7	0.055	0.067
L1	2.90 REF.		0.114 REF.	
L2	0.75	1.35	0.030	0.053
L3	0.6	1.2	0.024	0.047
θ	0°	10°	0°	10°
θ1	5°	9°	5°	9°
θ2	25° REF.		25° REF.	



## Disclaimer

All product specifications and data are subject to change without notice.

For documents and material available from this datasheet, Wuxi Unigroup does not warrant or assume any legal liability or responsibility for the accuracy, completeness of any product or technology disclosed hereunder.

No license, express or implied, by estoppels or otherwise, to any intellectual property rights is granted by this document or by any conduct of Wuxi Unigroup.

The products shown herein are not designed for use in medical, life-saving, or life-sustaining applications. Customers using or selling Wuxi Unigroup products not expressly indicated for use in such applications do so entirely at their own risk and agree to fully indemnify Wuxi Unigroup for any damages arising or resulting from such use or sale.

Wuxi Unigroup disclaims any and all liability arising out of the use or application of any product described herein or of any information provided herein to the maximum extent permitted by law. The product specifications do not expand or otherwise modify Wuxi Unigroup's terms and conditions of purchase, including but not limited to the warranty expressed therein, which apply to these products.

Wuxi Unigroup Microelectronics CO., LTD. strives to supply high-quality high-reliability products. However, any and all semiconductor products fail with some probability. It is possible that these probabilistic failures could give rise to accidents or events that could endanger human lives that could give rise to smoke or fire, or that could cause damage to other property. When designing equipment, adopt safety measures so that these kinds of accidents or events cannot occur. Such measures include but are not limited to protective circuits and error prevention circuits for safe design, redundant design, and structural design.

In the event that any or all Wuxi Unigroup products (including technical data, services) described or contained herein are controlled under any of applicable local export control laws and regulations, such products must not be exported without obtaining the export license from the authorities concerned in accordance with the above law.

Information (including circuit diagrams and circuit parameters) herein is for example only. It is not guaranteed for volume production. Wuxi Unigroup believes information herein is accurate and reliable, but no guarantees are made or implied regarding its use or any infringements of intellectual property rights or other rights of third parties.